

RASPBERRY PI BASED FARMING ROBOT WITH PLANT HEALTH INDICATION USING IMAGE PROCESSING

¹Prof. Avinash K. Ikhar, ²Prof. Firoz Akhtar, ³Dr. Pravin Kshirsagar, ⁴Milan Singh Baghel

³Associate Professor, ¹²Assistant Professor, ⁴Research Scholar

Department Of ECE

J D College of Engineering & Management, Nagpur

ABSTRACT

Agriculture is a most important and ancient occupation in India. As an economy of India is based on agricultural production, utmost care of food production is necessary. Virus, fungus and bacteria such pest causes infection to plants with loss in quantity and quality production. Because of that large amount of loss in production. Hence proper care of plants is necessary for same. This project presents an overview of Raspberry Pi based Farming Robot using Image Processing methods to detect various plant diseases. Farming Robot provides more efficient ways to detect diseases caused by fungus, bacteria or virus on plants. More observations by eyes to detect diseases are not accurate. Overdose of pesticides causes harmful chronic diseases on human beings. Nowadays due to spraying of pesticides on crop framers suffer from many chronic diseases that even caused death of farmer. Excess use also damages plants nutrient quality. It results in huge loss of production to farmer. Hence use of Raspberry Pi based Farming Robot using Image Processing methods to detect and classify diseases in agricultural applications is helpful.

I. INTRODUCTION

1.1 INTRODUCTION:

Agriculture is an ancient career. It performs a crucial role in our daily existence. Food is basic need of all people. To distribute meals among massive population desires proper amount of manufacturing. In India huge variety of populace lives in rural areas where livelihood of humans relies upon totally on agriculture. Accordingly Indian economic system on the whole relies upon on agriculture. Hence increasing first-rate production has grown to be necessary every day. Monitoring of crop/vegetation and their control from early degree is crucial. It consists of numbers of obligations like preparation of soil, seeding, including manure and fertilizer, irrigation, ailment detection, spraying pesticides, harvesting and garage. Among these spraying proper amount of pesticides needs to be taken proper care.

Pesticides are used to attract, seduce and break pests subsequently known as crop protection product. Pesticides are prepared by using dangerous chemicals or every so often by using organic strategies to kill pests, weeds or infections on plant. India is a cultivated country and approximately 70% of the populace depends on agriculture. Farmers have massive range of variety for choosing diverse suitable vegetation and finding the suitable pesticides for plant. Disorder on plant results in the large reduction in both the satisfactory and quantity of agricultural merchandise. The studies of plant ailment confer with the research of visually observable patterns at the plant life. Tracking of fitness and sickness on plant perform a vital role in a success cultivation of vegetation within the farm. In early days, the monitoring and analysis of plant diseases have been finished manually by using the information individual in that field. This call for first rate amount of work and additionally calls for excessive processing time. The photograph processing techniques can be used within the plant sickness detection. In maximum of the cases sickness symptoms are seen on the leaves, stem and fruit. Today various means are available to increase yield in production and reduce human efforts. Technologies have been vastly developed and spread in all fields including agriculture. One of the inventions is agricultural Robot. Agricultural robot is an agricultural robot used for performing various agricultural tasks. It performs all sorts of agricultural tasks. This reduces human efforts, increases yield and decreases cost of labor. Due to which one gets healthy food. Deep neural networks are now the state-of-the-art machine learning models across a variety of areas, from image analysis to natural language processing, and widely deployed in academia and industry. These developments have a huge potential for medical imaging technology, medical data analysis, medical diagnostics and healthcare in general, slowly being realized. We

provide a short overview of recent advances and some associated challenges in machine learning applied to medical image processing and image analysis. Long before deep learning was used, traditional machine learning methods were mainly used. Such as Decision Trees, SVM, Naive Bayes Classifier and Logistic Regression.

These algorithms are also called flat algorithms. Flat here means that these algorithms can't normally be applied directly to the raw data (such as .csv, images, text, etc.). We need a preprocessing step called Feature Extraction.

The result of Feature Extraction is a representation of the given raw data that can now be used by these classic machine learning algorithms to perform a task. For example, the classification of the data into several categories or classes.

Feature Extraction is usually quite complex and requires detailed knowledge of the problem domain. This pre-processing layer must be adapted, tested and refined over several iterations for optimal results. On the other side are the artificial neural networks of Deep Learning. These do not need the Feature Extraction step. The layers are able to learn an implicit representation of the raw data directly and on their own. Here, a more and more abstract and compressed representation of the raw data is produced over several layers of artificial neural-nets. This compressed representation of the input data is then used to produce the result. The result can be, for example, the classification of the input data into different classes.

1.1 BLOCK DIAGRAM:

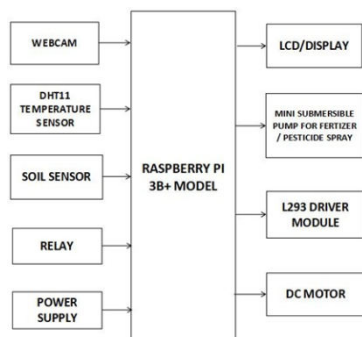

Figure.1: Block Diagram

1.2.1 FUNCTION OF THE COMPONENTS:

RASPBERRY PI 3B+ MODEL:

The Raspberry Pi 3 Model B+ is the latest product in the Raspberry Pi 3 range, boasting a 64-bit quad core processor running at 1.4GHz, dual-band 2.4GHz and

5GHz wireless LAN, Bluetooth 4.2/BLE, faster Ethernet, and PoE capability via a separate PoE HAT. The dual-band wireless LAN comes with modular compliance certification, allowing the board to be designed into end products with significantly reduced wireless LAN compliance testing, improving both cost and time to market. The Raspberry Pi 3 Model B+ maintains the same mechanical footprint as both the Raspberry Pi 2 Model B and the Raspberry Pi 3 Model B.

DHT11 TEMPERATURE & HUMIDITY SENSOR:

The DHT11 is a commonly used Temperature and humidity sensor that comes with a dedicated NTC to measure temperature and an 8-bit microcontroller to output the values of temperature and humidity as serial data. DHT11 is a low-cost digital sensor for sensing temperature and humidity. This sensor can be easily interfaced with any micro-controller such as Arduino, Raspberry Pi etc... to measure humidity and temperature instantaneously.

DHT11 humidity and temperature sensor is available as a sensor and as a module. The difference between this sensor and module is the pull-up resistor and a power-on LED. DHT11 is a relative humidity sensor. To measure the surrounding air this sensor uses a thermistor and a capacitive humidity sensor.

SOIL MOISTURE SENSOR:

The soil moisture sensor is one kind of sensor used to gauge the volumetric content of water within the soil. As the straight gravimeter dimension of soil moisture needs eliminating, drying, as well as sample weighting. These sensors measure the volumetric water content not directly with the help of some other rules of soil like dielectric constant, electrical resistance, otherwise interaction with neutrons, and replacement of the moisture content.

The relation among the calculated property as well as moisture of soil should be adjusted & may change based on ecological factors like temperature, type of soil, otherwise electric conductivity. The microwave emission which is reflected can be influenced by the moisture of soil as well as mainly used in agriculture and remote sensing within hydrology.

L293 DRIVER MODULE:

L293D is a typical Motor driver or Motor Driver IC which allows DC motor to drive on either direction. L293D is a 16-pin IC which can control a set of two DC motors simultaneously in any direction. It means

that you can control two DC motor with a single L293D IC. Dual H-bridge Motor Driver integrated circuit (IC). The L293d can drive small and quiet big motors as well, check the Voltage Specification at the end.

MINI SUBMERSIBLE PUMP:

Submersible pumps are efficient for pumping out septic tanks. Fluid is transferred into hoses to storage tanks and taken to a treatment facility. Submersible pumps are often used to pump excess water from work sites or flooded basements on construction sites. They can also be used to pump. Submersible pumps are centrifugal pumps whose hydraulic components (pump casing, impeller, diffuser element) are flooded by the fluid handled. Usually, this type of pump is not fitted with a suction line. A submersible pump whose motor is arranged above the floor is referred to as a vertical shaft submersible pump

RELAY:

A power relay module is an electrical switch that is operated by an electromagnet. The electromagnet is activated by a separate low-power signal from a micro controller. When activated, the electromagnet pulls to either open or close an electrical circuit. The relay module function is mainly to switch electrical devices and systems on or off. It also serves to isolate the control circuit from the device or system being controlled.

WEB CAM:

A webcam is a video camera which is designed to record or stream to a computer or computer network. They are primarily used in video telephony, live streaming and social media, and security. Webcams can be built-in computer hardware or peripheral devices, and are commonly connected to a device using USB or wireless protocols. Webcams have been used on the Internet as early as 1993, and the first widespread commercial one became available in 1994. Early webcam usage on the Internet was primarily limited to stationary shots streamed to web sites. In the late 1990s and early 2000s, instant messaging clients added support for webcams, increasing their popularity in video conferencing. Computer manufacturers also started integrating webcams into laptop hardware. In 2020, the COVID-19 pandemic caused a shortage of webcams due to the increased number of people working from home.

JUMPER WIRES:

Jumper wires are electrical wires with connector pins at each end. They are used to connect two points in a circuit without soldering. You can use jumper wires to modify a circuit or diagnose problems in a circuit. Further, they are best used to bypass a part of the circuit that does not contain a resistor and is suspected to be bad. This includes a stretch of wire or a switch. Suppose all the fuses are good and the component is not receiving power; find the circuit switch. Then, bypass the switch with the jumper wire. How much current (I) and voltage (V) can jumper wires handle? I and V rating will depend on the copper or aluminium content present in the wire. For an Arduino application is no more than 2A and 250V. We also recommend using solid-core wire, ideally 22 American Wire Gauge (AWG).

9V BATTERY:

This is General purpose 9V Original HW Non-Rechargeable Battery for all your project and application needs. As we experienced the use of this battery in our testing lab for various purpose, we can assure you the best quality, long life and genuineness of this battery among all options available in the market at this cost. Its Universal 9V battery size and connecting points; it is useful in many DIY projects as well as household applications and they can easily be replaced and installed; the same as you would an AA battery or an AAA battery.

DC MOTOR:

A DC motor is any of a class of rotary electrical motors that converts direct current (DC) electrical energy into mechanical energy. The most common types rely on the forces produced by induced magnetic fields due to flowing current in the coil. Nearly all types of DC motors have some internal mechanism, either electro mechanical or electronic, to periodically change the direction of current in part of the motor.

II. LITERATURE SURVEY

1. The Leaf Disease Diagnosis and Pesticide Spraying Using Agricultural Robot that Plant diseases have created an immense post-effect scenario as it can significantly reduce agricultural products in terms of both quality and quantity. Early detection of pests is a big issue that concerns planting crops. First phase includes plant observation keenly and frequently. Then the infected plants will be identified and photographs will be collected using

camera for the infected portion of the plants. Then these images are pre-processed, transformed and clustered further sent to the processor as input, and the images are compared by the processor.

On the basis of literature review carried out and find a need to develop a system which gives the better ways to control the production of crops, the modified robot checks the disease with help of image processing and also check the temperature of the plant and moves forward to check the other plants. The proposed system will identify the plant disease and it will display the name of the disease.[1]

2. In this Literature an Agricultural robot is used to move around the field and captures the image of the leafs and perform the disease detection operation. Using soil sensor soil moisture can be measured. Here DHT11 Temperature and humidity sensor are used to measure the plant health. A camera is placed and it captures the images that is transferred to the system. The captured images are run on Raspberry pi for detection of the disease. The infected disease name will be displayed. After the detection of the disease pesticide sprayer is used for spraying of the pesticide. The main objective of this literature is to reduce the cutting of plants and helps the proper detection to identify the plants disease, so that the pesticides are spared on effected plants.[2]

III. OUTPUT PANEL:

This Output Panel is used to give comments about the code.

- 1) If the code is successfully compiled or any error occurs.
- 2) If the code has been successfully uploaded to the board.

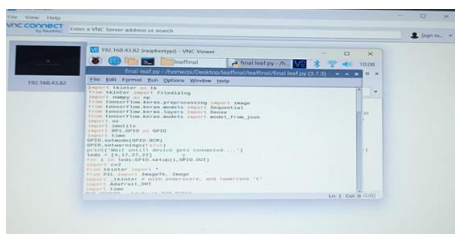

Figure 2: Output panel

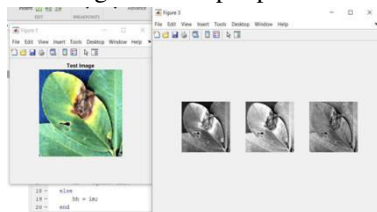

Figure 3: Image Capturing and preprocessing

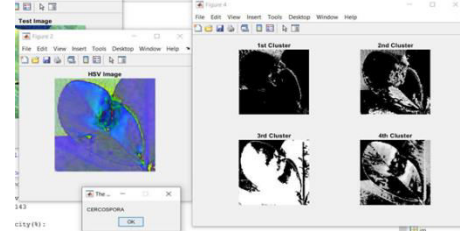

Figure 4: Decomposing the Captured image

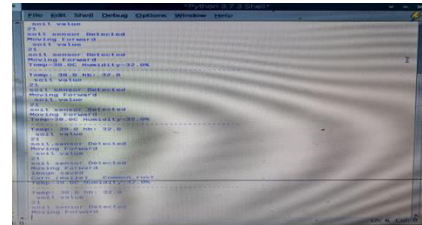

Figure 5: Result Terminal

3.1 PROGRAM FLOWCHART:

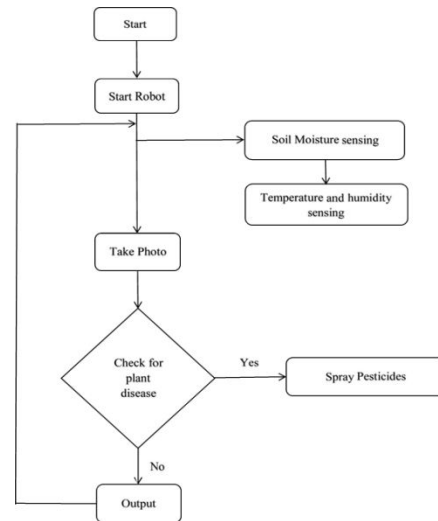

Figure 6: Program Flowchart

IV. PROJECT WORKING & RESULT

4.1 CIRCUIT DIAGRAM:

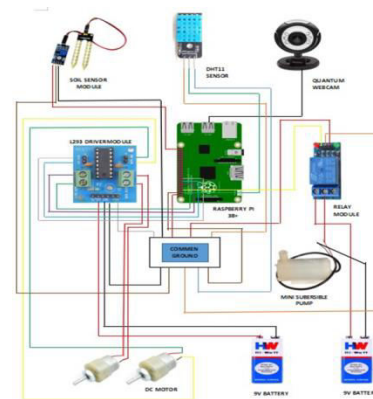

Figure 7: Project Circuit Diagram

4.2 RESULT:

4.2.1 PROJECT MODULE:

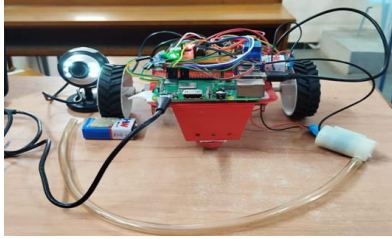

Figure 8: Project Module

4.2.2 WORKING:

1. The module “Raspberry Pi based Farming robot with plant health indication using image processing”, works on image processing which detects the disease of the plant.
2. The robot moves, checks for the plant and captures the effected image of leaf, then the captured image is processed for detection of disease and gets clustered. Then further it is transferred to the system and the disease of leaf is displayed.
3. With the use of Soil sensor the module checks the moisture of the soil, using DHT11 sensor the Temperature and Humidity are measured.
4. If any disease is detected then the robot spray’s the pesticides to that infected plant.

4.3 ADVANTAGES:

- Reducing direct exposure to pesticides and the human body and improve production efficiency.
- Good coverage and penetration, high capacity, and options to spray at high or low volumes.
- This increases the productivity and reduces cutting of plants whether to carry on or to cut the plant leaves with knowing the plant disease.
- Nowadays, image detection or image processing is widely used in a wide range of agricultural tasks. These jobs include soil assessment, irrigation, leaf analysis, weed detection, pest control, disease recognition, vegetation measurement, monitoring plant growing, and fruit/food grading.

4.4 DISADVANTAGES:

- Drift hazards, unsuitable for windy conditions or for use in small areas, and high cost.
 - It costs a lot of money to make or buy robots, Energy cost and maintenance.
 - They need maintenance to keep them running.
 - The robots can change the culture / the emotional appeal of agriculture.
- The high cost of research and development.
- Lack of access to poor farmers.

4.5 APPLICATIONS:

- This project module utilized for agricultural purpose where the farmers can make use of it.
- This project module used for identifying the exact plant disease using image processing on plant health.
- This module used for increasing the productivity and reduces cutting of plants whether to carry on or to cut the plant leaves with knowing the plant disease.

V. FUTURE SCOPE & CONCLUSION

5.2 CONCLUSION:

The proposed project “RASPBERRY PI BASED FARMING ROBOT WITH PLANT HEALTH INDICATION USING IMAGE PROCESSING” is successfully designed, and tested and the demo unit is fabricated. The system utilizes picture handling to watch the leaf shading which increments facilitate exactness of the module as it identifies shading precisely than human. This module additionally watches distinctive natural conditions such as moisture, soil dampness and temperature which human can't quantify precisely by open eyes to choose the plant well being so the exactness of the project module is high. It likewise includes watering component and cutting process which decreases human work and we can lessen work advance by adjusting the frame work encourage for other farming work, for example, picking.

5.1 FUTURE SCOPE:

- We can build robots exactness of identification of leaf shading effectively by utilizing high quality camera.
- Wire-less System. We can make this module remotely by utilizing RF connectors.
- This module can additionally altered for picking organic products, and real cutting procedure.

REFERENCES

- [1] Rakesh Kumar, M.P. Singh, Prabhat Kumar and J.P. Singh, “Crop Selection Method to Maximize Crop Yield Rate using Machine Learning Technique”, 2015 International. Conference on Smart Technologies and Management for Computing, Communication, Controls, Energy and Materials (ICSTM), 6 - 8 May 2015. pp.138-145.

M. Young, The Technical Writer's Handbook. Mill Valley, CA: University Science, 1989.

[2] Implementation of Image Processing in Detection of Plant Diseases, by Shivani Walia, Tanmay Aggarwal, Bharat Sharma, Paurush Bhulania • 2020.

[3] Bhavana Patil, "Plant Monitoring Using Image Processing, Raspberry Pi Iot ", Irjet, Volume 4 2017.

[4] Ganesh P., Tamilselvi K., Karthi P., "Crop Prediction by Monitoring Temperature and Rainfall Using Decision Tree with Iot and Cloud Based System", IOSRJEN, ISSN (p): 2278-8719.

[5] K.Lakshmisudha, "Smart Precision Based Agriculture Using Sensors", International Journal Of Computer Applications, Volume 146,2016.

[6] Disease Detection in Crop using Image Processing by Prof. Mrs. Smita desai, Dr. Rajendra D Kanphade, Er Varunn Jain 2022.